

# A Human-Computer Interface based on Forehead Multi-Channel Bio-signals to Control a Virtual Wheelchair

S. Mohammad P. Firoozabadi<sup>1,2</sup>, Mohammad Reza Asghari Oskoei<sup>2</sup>, Huosheng Hu<sup>2</sup>

<sup>1</sup>*School of Medical Science, Tarbiat Modares University, Tehran, Iran*

Email: [pourmir@modares.ac.ir](mailto:pourmir@modares.ac.ir)

<sup>2</sup>*Department of Computer Science, University of Essex, Colchester CO4 3SQ, United Kingdom*

Email: {[smpour](mailto:smpour@essex.ac.uk), [masgha](mailto:masgha@essex.ac.uk), [hhu](mailto:hhu@essex.ac.uk)}@essex.ac.uk

**Abstract** - The goal of Human-Computer Interface (HCI) (Human-Robot interface HRI) research is to provide humans with a new communication channel that allows translating Human's will states via a computer into application specific actions. This paper presents a novel hands-free control system for controlling a virtual wheelchair, which is based on Forehead Multi-channels Bio-signals as EMG (Electromyogram) signals. In this method, new locations for three Bi-polar electrodes are selected. The Bioelectric signals are picked up from lateral sides and centre of Forehead then the Bio-signals are passed through a band pass filters. Motion control commands (forward, left, right, backward and stop) are classified by SVM method. These commands are used for controlling the virtual wheelchair by interface software in a Personal Computer.

**Index Term**- Hands-free control, Multi-Channel EMG, Forehead Bio-signals, SVM.

## I. INTRODUCTION

One of the major challenges for prosthesis or Human-Robot Device development is to produce devices to perfectly mimic their natural counterparts. A very popular approach for prosthesis or Robot control is based on the use of Bio-signals. One of them is EMG (the electrical manifestation of the neuromuscular activation associated with a contracting muscle) collected from remnant or normal muscles and use them as control inputs for the artificial limb or Robot Device. As these devices, known as EMG-based Hands-Free Wheelchair [1] use a biological signal to control their movements, it is expected that they should be much easier to control.

Power wheelchairs play a significant role in the rehabilitative activities. They are used predominantly by people with both lower and upper extremity impairment resulting from cerebral palsy, high-level spinal cord injury, or muscular dystrophy. Many of disabled persons use power wheelchairs to manoeuvre in their residential, institutional or official area, in order to communicate with their society more conveniently. There are over 200,000 power wheelchair users in the U.S. alone [2]. Although today's various control interfaces and microprocessor's usage make it easier to navigate a wheelchair, persons with severe and/or multiple disabilities may yet find it extremely difficult to steer a power wheelchair in their favourite directions and with an ideal

quality. A recent survey of 200 practicing clinicians indicates that many consumers have difficulty controlling power wheelchairs [3]. Results reported in the survey show that, according to clinicians, nearly half of the people unable to control a power wheelchair by conventional methods can benefit from an automated navigation system. The aim of the intelligent wheelchairs is to make wheelchairs able to be controlled and navigated with the minimal interaction with the users, in order to enhance the quality of service for the handicaps. According to the studies, the methods used for commanding in wheelchairs are: joystick(81%), head or chin control(9%), sip and puff(6%), eye gaze, tongue pad, head, hand and foot switch control (totally 4%) [3]. In addition to easy transferring of command to the system, users need to conform motion quality according to their physical abilities. In the other words, they should be able to select the mode of navigation, including rising time, falling time, maximum and minimum of speed and profile of speed's changes. We should notice that wearing of components in the motor and derive system during usage; various environmental situations and user's weight are the significant factors that cause considerable changes in the operation of open loop system. So a suitable control module in the wheelchair must provide the output selected by users under any external-induced conditions.

In our pervious studies, we have designed and fabricated an automatic wheelchair with a signal processing section to recognize the motion commands from Muscles of neck [1] and forearm [7] of the users who can not use the joystick.

In this study, a new method of Bio-Electric control of Virtual Wheelchair is presented. New locations for three Bi-Polar electrodes are selected. Beside, the EMG-Based Wheelchair control is very unnatural and requires a great mental effort, especially during the first Week after fitting. It is difficult to keep the subjects' motivation to recover or improve their functioning ability. As a result, a number of patients give up the use of those devices very soon. Therefore, rehabilitation training process without losing the patients' interest is required. Therefore, in this work we are going to emerge an attempt to devise better strategies for EMG-Based control and a better technique to be used in that critical initial term of training, by the virtual control. This involves better methods for detection, and processing the EMG signals.

## II. MATERIAL AND METHOD

### A. System Architecture

Figure 1 shows the formal scheme for the acquisition and analysis of the EMG signal for the control organization and flow of information through the system. The EMG signal detected by surface electrodes is amplified and filtered prior to data acquisition, in order to reduce noise artefacts and/or enhance spectral components that contain information for data analysis. Also to process the correct section of the acquired signal, it is necessary to find out where the EMG activity starts and ends and extract that portion (windowing). The resulting signal is then processed to generate the features that will be used by a SVM Classifier to classify the EMG signal. The output of the SVM classifier can then be used to evaluate and activate the correct function of a virtual wheelchair.

### B. Location of Electrodes for Measuring EMG

Head movement is a natural form of gesture and can be used to indicate a certain direction [1]. Serious disabled people can not move neck and head, but can get face figures. Electromyography (EMG) is a way of studying facial muscles activities by recording action potentials from contracting fibres. EMG can be detected with surface electrodes. Surface electrodes are easy to apply. This is a non-invasive way to record EMG while posing no health and safety risk to the users. Three Channels of EMG signals can be used to recognize face figure movement (Figure 2) according to smile movement. As disabled people with spinal cord injury, specially, Frontalis muscle shows a contraction in tensing eyebrows upwards and Zygomatic muscle shows a contraction in the retracting lip corners upwards (Figure 2).

The utilized face movements, command classes and effective channels of forehead bio-signals are defined in Table 1.

TABLE I

The input pattern and classes of our design

Command	Motion	Effective Channels
Turn Right	Retracting and pulling the Right lip corners upwards	1
Turn Left	Retracting and pulling the Left lip corners upwards	3
Forward	Smile: Retracting and pulling the two lip corners upwards	1 and 3
Backward	tensing eyebrows, pulling eyebrows up	2
Stop	Relaxing Facial Muscles	1, 2 and 3

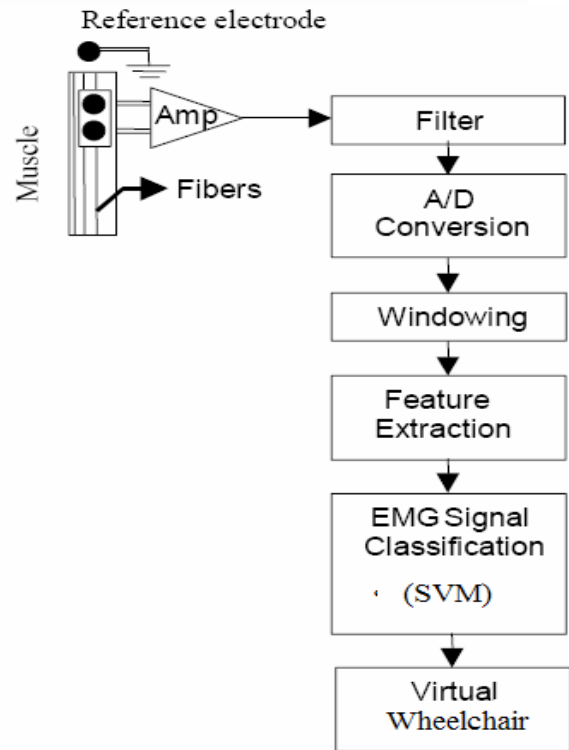

Fig.1 - System Architecture

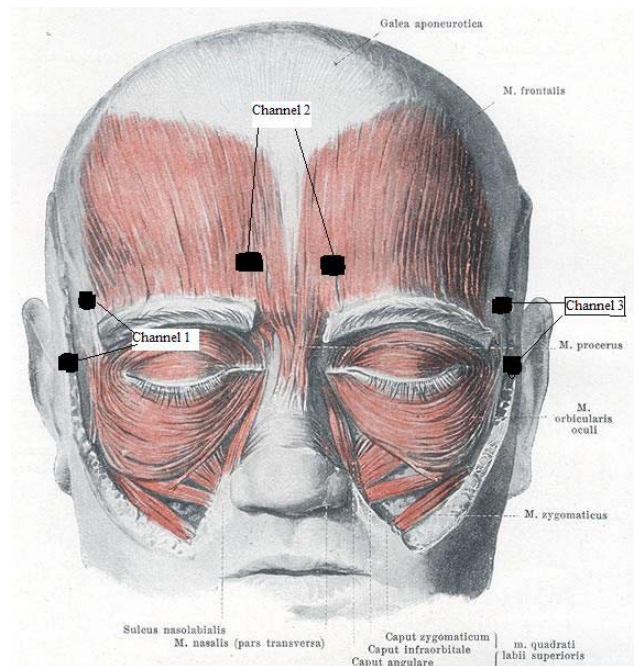

Fig. 2 - Locations of three Bipolar electrode (or Bio-signal Channels) and The muscles of the upper face include the following: Frontalis (pulls the eyebrows up), Zygomatic (retracts and pulls the lip corners upwards), Procerus or Pyramidalis (pulls the glabella down), Orbicularis oculi (squints the eyes) consists of two major parts: an outer part; the inner part, mostly on the eyelids, Nasalis transverse or compressor part (compresses the nostrils), Quadratus labii superioris (a muscle in the medial cheek and nose are that has multiple strands).

### C. EMG Signal Processing

Our EMG pattern recognition procedure consists of four main parts: data acquisition, pre-processing, feature extraction, and classification.

For EMG recording, we utilize bipolar active Electrodes (Biometrics Ltd SX230). The active electrodes has pre-amplifier to differentiate small signal of interest and much larger interference signals that present on the skin. The signals are filtered by Band pass filter with range 3-450Hz and pickup filter to remove unwanted line frequencies. An electrode was also placed on the wrist providing a common ground reference. Signals were sampled at 1000 Hz using a 12-bit A/D converter and map linearly from  $\pm 100\text{mV}$  into  $\pm 1$  with resolution 0.0001.

Processing the EMG signal is an exceedingly difficult task. When working with this kind of signal one must bear in mind that it is a stochastic (or regarding to some other papers chaotic) process that doesn't have a formal rule of formation and its shape varies frequently. One of the main purposes of this work is to apply a systematic methodology for extracting the appropriate (and correct) features of the EMG signal in order to use them as input to a SVM classifier [7]. The results of the SVM, as mentioned earlier, can then be used to decide which function should be performed by a device. As the acquired signal may contain areas of inactivity, it is important to find out the correct EMG envelop. This was achieved by searching the beginning and the end of the EMG activity and using a windowing method (in this case a rectangular window) to extract the correct portion. One strategy is to find out the limits of the EMG activity is based on a threshold value for the variance of the signal. The next step is to decide for the correct features to be extracted from the EMG signal. Those features must contain enough information to represent the EMG signal adequately and also must be simple enough for fast training and running of the SVM classifier. The EMG signals were divided into several time segments to preserve pattern structure, and features were extracted from these segments. A segment is a time slot of acquiring EMG data considered for feature extraction. Due to real time constraints, a segment length plus the processing time of generating classified control commands should be equal or less than 300ms [4]. Besides segment length and data state (transient and steady), a third important point in data segmentation is the data windowing techniques (adjacent and overlapped). This work used 200ms segment length in adjacent windowing with steady state signal in real time control of virtual wheelchair.

Features are the most challenging point in pattern recognition problems, because they should be adequately consistent with the classifier. Meanwhile, due to time constraint in real-time control, most distinctive features should be selected to feed to the classifier. EMG features were evaluated by using Davies-Bouldin index, scattering criterion and K-nearest neighbour nonparametric classifier. One of the best, simplest features is Mean Absolute Value (MAV) [9].

$$\text{MAV} = 1/N \sum |\text{EMG}(i)| \quad (1)$$

This feature is time-domain (TD) feature calculated based on amplitude of signal and gives a measure of signal energy. TD features comparing with frequency-domain (FD) features require less computation and time to be calculated.

### D. EMG Signal Classifier

EMG pattern recognition has been applied in controlling devices. The control is based on the fact that subject are able to generate a repeatable (although perhaps gradually varying) EMG pattern corresponding to each of the functions. In the past decades, much research has been done on the recognition of EMG signals, most of which has been reviewed by Hudgins [5] and [4], etc. The main Wheelchair control functions of interest were Turn Left, Turn Right, Forward and Backward of the wheelchair respectively. The low and high speeds were also of some interest. In order to differentiate these control functions, investigators developed various EMG features which include EMG signal amplitude, zero-crossing, EMG frequency characteristics, and coefficients of an EMG autoregressive model. The classification tools covered linear discriminate functions, neural networks, fuzzy systems [1][5] and SVM [7]. Researchers have applied different kinds of mathematical models and pattern recognition techniques to the problem; however, they are not yet commercially available.

EMG classification systems as listed above suffer from one or more of the following drawbacks: large number of electrodes; sensitivity to electrode displacement; low recognition rate; perceivable delay in control (delay 300 ms; a 200 to 300 ms interval is a clinically recognized maximum delay that users find acceptable before they get frustrated with the slow response of the prosthesis. However, its recognition rate is subject-dependent, ranging from 70 to 98%. However, it should be notified that the success of the method is chiefly due to the appropriately selected features.

Although the emphasis here is not on the classifier, one of the new approaches for classification is SVM approach. SVM systems are advantageous in biomedical signal processing and classification. Biomedical signals are not always strictly repeatable, and may sometimes even be contradictory. Support Vector Machine (SVM) is a relatively novel approach with the strong theoretical background that has become an increasingly popular tool for machine learning tasks involving classification and regression. It has recently been successfully applied into the several applications ranging from face identification and text categorization to bioinformatics and database mining. SVM constructs an optimal separating hyper plan in high dimensional feature space of training data that are mapped by a non-linear kernel function. Thus, although it uses linear learning machine method with respect to non-linear kernel function, it is in effect of non-linear classifier. The use of non-linear kernel function greatly increases the power of learning and generalization. This, as well, can increase the risk of over fitting which may lead to bad generalization and that's

why, the flexibility of kernel-induced feature space is controlled by setting an upper band for generalization risk. Hence, SVM outperforms other classifiers in generalization performance and performs robustly.

Training in SVM involves optimization of a convex cost function, there are relatively few free parameters to adjust and the architecture does not have to be found by experimentation. The approach is systematic and motivated by statistical learning theory and Bayesian arguments. The constructed model has an explicit dependence on the most informative patterns of data (support vectors). SVM is binary classification, so for multi-class classifications the pair-wise classifications such as one-against-all or one-against-one can be used. This paper proposes a SVM approach for EMG recognition based on most of the same time-segmented features as used by.

### V. EXPERIMENTAL RESULTS

The subjects were one adult (44 years old) and two children (10 and 13 years old) healthy non-athletic male with no history of serious disorder. Subjects participate in three separate sessions. In each session, the subject contracts the facial muscles to produce four motions according to table I for about four seconds. Figure 3 shows Activation levels of three channels EMG in a Sequential commands (Right, Left, Forward, and Backward) for the Adult Subject. Figure 4 shows Activation levels of three channels EMG in the Sequential commands for a Child (PA). Children have not capability to produce adequate facial figures and facial muscle contractions. Consequently, Children Bio-Signals have overlap on three channels EMG (figure 4), but SVM classifier can be clustered these overlapped classes.

In the previous work, the system's correct classification rate was between 95% and 100% [1]. In this work, we used Bio-signals of two experimental Sessions for training of the SVM classifier and EMG Signals of third experimental session for testing of classification accuracy. Tables II shows the SVM classification results for the three subjects.

TABLE II  
Accuracy of SVM Classification

Subject no.	Accuracy
1 (Adult)	100%
2 (Child PA)	89.75%
3 (Child PO)	97.49%

After classification sessions, Subjects were tested at fourth session. In this session, Subject controls the virtual wheelchair in a virtual box (400 X 330 Pixel) as shown in Figure 5. The task is to drive the virtual wheelchair from position A to B by contraction of Facial Muscles. In this experiment, Virtual Interface software and Data acquisition and processing programs are executed on a Personal computer, concurrently. This virtual control is performed real-time. Distance from A to

B is 400 pixels and maximum speed of the virtual wheelchair is set 13.5 pixels per second.

The experiment was repeated 5 times as shown in table III without any pre-training Session.

TABLE II  
Testing results over five runs for Adult Subject.

Run ID	Seconds
1 <sup>st</sup>	50.6
2 <sup>nd</sup>	42.7
3 <sup>rd</sup>	43.0
4 <sup>th</sup>	38.9
5 <sup>th</sup>	41.5
Average	43.32
Average speed of the virtual wheelchair is 9.8 pixels per second in these Experiments.	

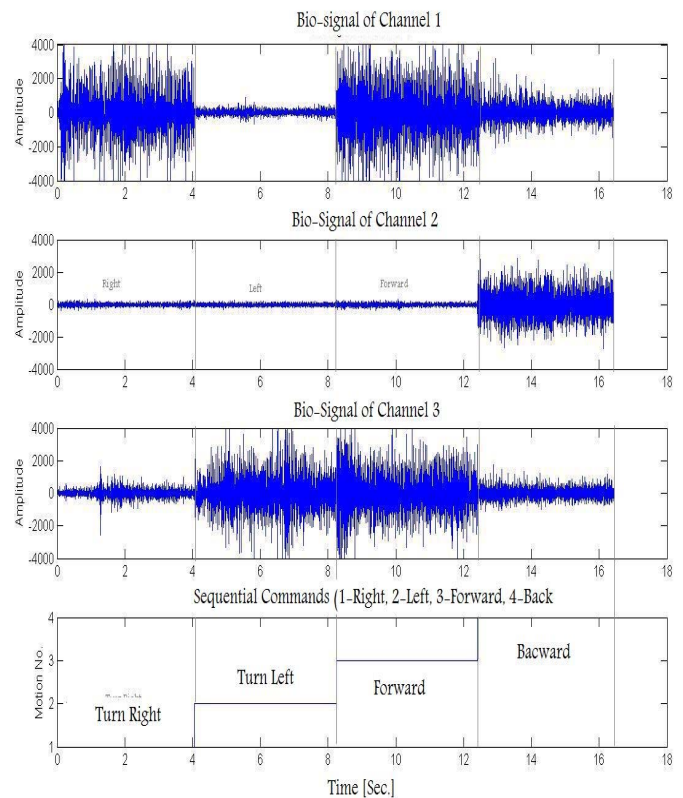

Fig. 3 Activation levels of three channels EMG for Adult Subject.

VI. DISCUSSION AND CONCLUSION

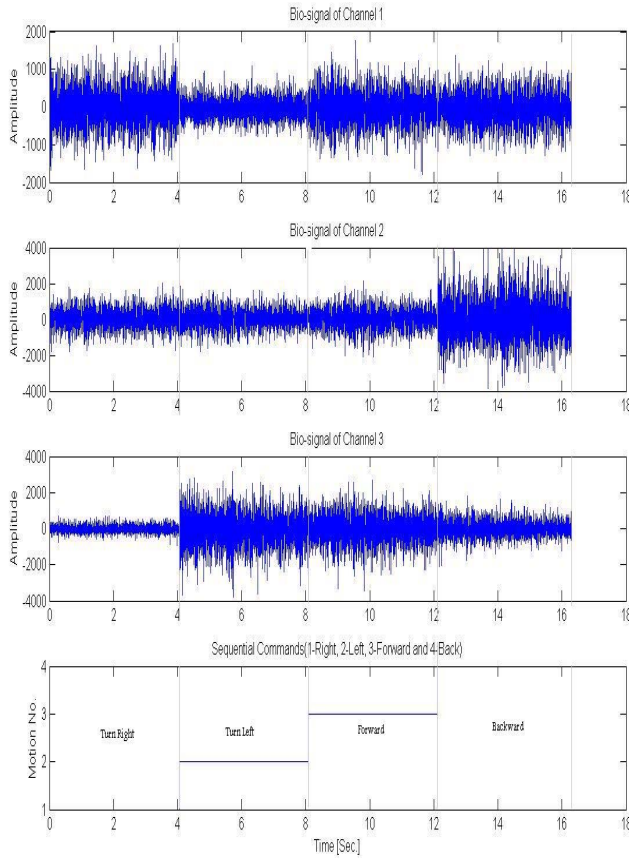

Fig. 4 Activation levels of three channels EMG for Child Subject (PA).

It should be noted that this paper presents primary stage of our research. With advancement of effective bio-signal processing techniques, however, some of the difficulties may be overcome for limited Human-Robot (or Computer) interaction HRI (or HCI) applications. First, note that efficient acquisition and use of various human bio-signals are essential in human-friendly HRI to recognize human's behaviour and physical status as well as understand human intention (Figure 6). Human bio-signals include body gestures such as hand gesture and some physiological bio-signals such as EMG, EEG, EOG and ECG. Note that, as long as modelling is concerned, such signals show quite complicated characteristics such as high dimensionality, nonlinear-coupling of attributes, subjectivity, apparent inconsistency, susceptibility to environmental noise and disturbances, and time-variance as well as situation-dependency [10]. In the future, it would be useful to utilize an advanced normalizing method to make the signal processing approach independent from user individual characteristics.

As such, building a human model from diverse and complex sources of information would be a very challenging task when it is to be used for human-friendly interaction in various situations for a long time [11]. We should further improve in some ways. For instance, the system would increase wheelchair speed only if there is enough space in front of the wheelchair, based on information provided by the Extra class extraction on these three Bio-signals channels. Furthermore, our goal is to extract EEG and EOG related information from these channels. Then Human Computer Interface can be developed to identify Human disturbed-states or/and bad Psychological states of subjects to control the device in external-induced conditions.

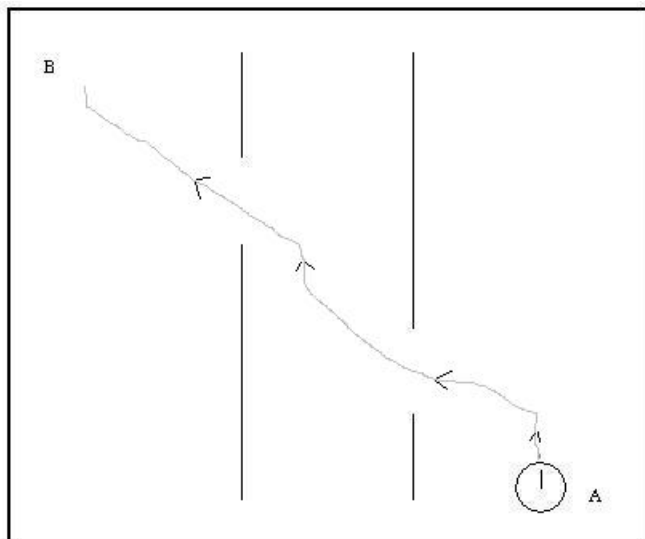

Fig. 5 Testing Environment.

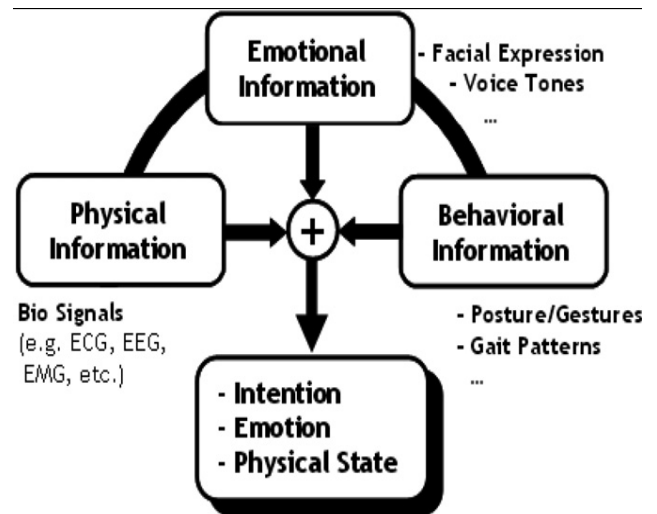

Fig. 6 Variety of information on human model for interaction [11].

Consequently, in this research, we designed and fabricated a virtual wheelchair using integration of forehead multi-Channel EMG signal processing. We examined our design to control a wheelchair in the phantom spaces. The results are satisfactory and most of the users (one adults and two children), even, who can use their Face for commanding, said that applying such a wheelchair is convenient and able to control and navigate with the minimal interaction with them.

[11] Z. Zenn Bien \*, Hyong-Euk Lee, "Effective learning system techniques for human-robot interaction in service environment," Knowledge-Based Systems, vol. 20, pp. 439-456, 2007.

#### REFERENCES

- [1] A. Assareh, S. Konjkav, A. Fallah, S.M.P. Firoozabadi, "A New Approach for Navigating Automatic Wheelchairs using EMG Signals Feature Extraction and Classification with an Adaptive Controller," in Proc. The 12th International Conference on Biomedical Engineering, SINGAPORE, Dec. 2005.
- [2] Dan Ding, Rory A. Cooper, "Electric-Powered Wheelchairs, A Review of Current Technology and Insight into Future Direction", IEEE Control System Magazine, pp. 22-33, April 2005.
- [3] L. Fehr, W.E. Langbein, and S.B. Skar, "Adequency of Power Wheelchair Control Interface for Persons with Severe Disabilities: A Clinical Survey," J. Rehab. Res. Dev., vol.37, No.3, pp.353-360, 2000.
- [4] Mohammadreza Asghari Oskoei, H. Hu, "Myoelectric Control Systems- A Survey," Biomed. Signal Process. Control, 2007, in Press.
- [5] B. Hudgins, P. Parker and R. N. Scott, "A New Strategy for Multifunction Myoelectric Control," IEEE Transactions on Biomedical Engineering, 40, (1), pp. 82-94, 1998.
- [6] S. Abe and M.-S. Lan, "A Classifier Using Fuzzy Rules Extracted Directly from Numerical Data," Proc. 2nd IEEE International Conference on Fuzzy Systems, San Francisco, pp. 1191-1198, March 1993.
- [7] M. Asghari Oskoei, Huosheng Hu, "Application of Support Vector Machines in Upper Limb Motion Classification," in Proc. IEEE International Conference on Robotics and Biomimetics (ROBIO2007), Sanya, China, Dec. 2007.
- [8] Chun Sing Louis Tsui, Pei Jia, John Q. Gan, Huosheng Hu and Kui Yuan, "EMG-based Hands-Free Wheelchair Control with EOG Attention Shift Detection," in Proc. IEEE International Conference on Robotics and Biomimetics (ROBIO2007), Sanya, China, Dec. 2007.
- [9] M. Asghari Oskoei, Huosheng Hu, "Evaluation of reparability Measures in GA-based Feature Subset Selection for Myoelectric Classification," in Proc. 13<sup>th</sup> Iranian Conference on Biomedical Engineering, (ICBME2007), Tehran, Iran, 2007, pp 188-193.
- [10] Z. Bien, " Learning techniques in service robotic environments, applied artificial intelligence, " in Proc. of Seventh Int'l FLINS Conference, Genoa, Italy, 2006.